

 MITSUBISHI

black
DIAMOND



CCD COLOR CAMERA

BDC4803H

USER MANUAL



CONTENTS

| | | |
|---|---|----------------|
| - | PRECAUTIONS | Page 3 |
| - | PACKING CONTENTS | Page 4 |
| - | <u>1. User Manual</u> | Page 4 |
| - | <u>2. Camera</u> | Page 4 |
| - | <u>3. CS-Mount Adapter</u> | Page 4 |
| - | <u>4. Auto Iris Lens Connector</u> | Page 4 |
| - | FEATURES AND FUNCTIONS | Page 5 |
| - | INSTALLATION | Page 6 |
| - | <u>1. Power connection</u> | Page 6 |
| - | <u>2. Video cable</u> | Page 7 |
| - | <u>3. Installation of the Auto Iris Lens Connector</u> | Page 8 |
| - | <u>4. Mounting the Lens</u> | Page 9 |
| - | <u>5. Operating controls and functions</u> | Page 10 |
| - | SPECIFICATIONS | Page 11 |
| - | ADDRESS | Page 12 |

PRECAUTIONS

- 1. Do not attempt to disassemble the camera.**
There are no user serviceable parts inside. Ask a qualified service person for servicing
- 2. Handle the camera with care.**
Do not mishandle the camera. Avoid striking, shaking, etc. Improper handling or storage could damage the camera.
- 3. Do not expose the camera to rain or moisture, or try to operate it in wet areas.**
Turn the power off immediately and ask a qualified service person for servicing. Moisture can damage the camera.
- 4. Do not use strong or abrasive detergents when cleaning the camera body.**
Use a dry cloth to clean the camera when dirty. In case the dirt is hard to remove, use a mild detergent and wipe gently. Afterwards, wipe off the remaining part of the detergent with a dry cloth.
- 5. Clean the CCD faceplate with care.**
Do not clean the CCD with strong or abrasive detergents. Use lens tissue or a cotton tipped applicator and ethanol.
- 6. Never face the camera towards the sun. Do not aim the camera at bright objects.**
Whether the camera is in use or not, never aim it at the sun or other extremely bright objects. Otherwise, blooming or smear may be caused.
- 7. Do not operate the camera beyond the specified temperature, humidity or power source ratings.**
Use the camera in conditions where temperature is between $-10\text{ }^{\circ}\text{C} \sim +50\text{ }^{\circ}\text{C}$, humidity is below 80% without moisture and the power source is DC 12 V ($\pm 10\%$).

PACKING CONTENTS

1. User Manual

2. Camera

3. CS-Mount Adapter



4. Auto Iris Lens Connector

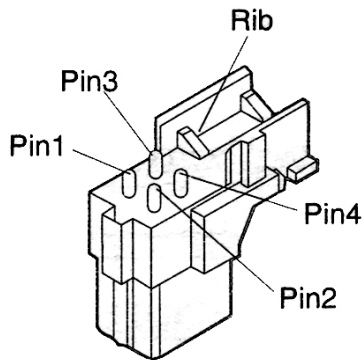

Auto Iris Lens Connector

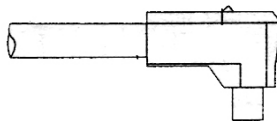

FEATURES AND FUNCTIONS

- Auto Light Control (ALC) function
- Electronic Light Control (ELC) function
- Automatic Gain Control (AGC) function
- Automatic Tracing White Balance (ATW) function
- Internal Synchronisation
- Minimum Illumination of 1 Lux @ F2.0
- Signal to noise ratio > 45 dB (AGC off)
- Horizontal resolution of 480 TV lines.
- Auto Iris Lens Control selectable between video signal – and DC power controlled.
- OLPF Built in
Unlike usual cameras, this camera filters unnecessary noise signals in dark view and transmits them with more clear picture signals. This makes it possible to eliminate unpleasant dark noises in low lux conditions and ensures an extraordinary clear picture in any light condition.

INSTALLATION

1. Power connection

Connect the DC 12V powercable with the DC 12V Terminal.

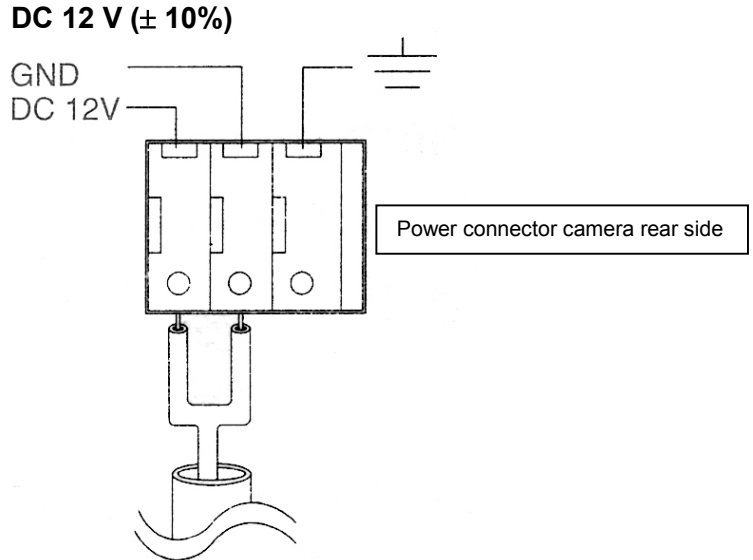

● Resistance of copper wire (at 20 °C)

| Copper wire size | 0,22 mm ² | 0,33 mm ² | 0,52 mm ² | 0,83 mm ² |
|------------------|----------------------|----------------------|----------------------|----------------------|
| Ω / m | 0,078 | 0,05 | 0,03 | 0,018 |

● Calculation of max. cable length between camera and power supply:

$$10,5V \text{ DC} \leq V - (R \times 0,42 \times L) \leq 16V \text{ DC}$$

L : Cable length (m)

R : Resistance of copper wire (Ω / m)

V : DC output voltage of power supply (V DC)

$$L \text{ standard} = V - 12 / 0,42 \times R$$

$$L \text{ min.} = V - 16 / 0,42 \times R$$

$$L \text{ max.} = V - 10,5 / 0,42 \times R$$

2. Video cable

- It is recommended to use a monitor with a resolution at least equal to that of the camera.

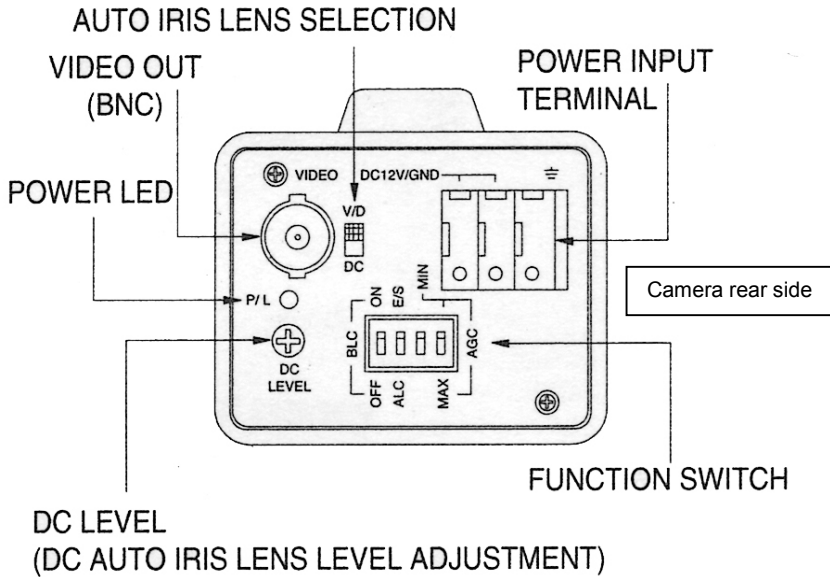

- The max. extensible coaxial cable length between camera and the monitor is shown below.

| Coax cable type | RG-59/U (3C-2V) | RG-6U (5C-2V) | RG-11/U (7C-2V) | RG-15/U (10C-2V) |
|-----------------------------------|--------------------|------------------|--------------------|---------------------|
| Recommended max. cable length (m) | 250 | 500 | 600 | 800 |

3. Installation of the Auto Iris Lens Connector

Install the lens connector (YFE4191J100) when using a video drive ALC lens. The installation should be made by qualified service personnel or system installers.

The pin assignment of the lens connector is as follows:

Signal for video iris lens :

- Pin 1: Power Source + 9V DC, 50mA max.
- Pin 2: Not used
- Pin 3: Video Signal; 1,3Vpp /40k
- Pin 4: Shield; ground

Signal for DC iris lens :

- Pin 1: DAMP -
- Pin 2: DAMP +
- Pin 3: DRV +
- Pin 4: DRV - (GRD)

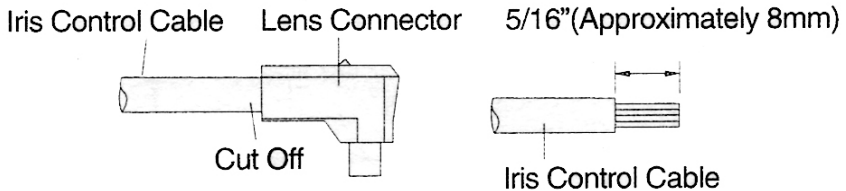
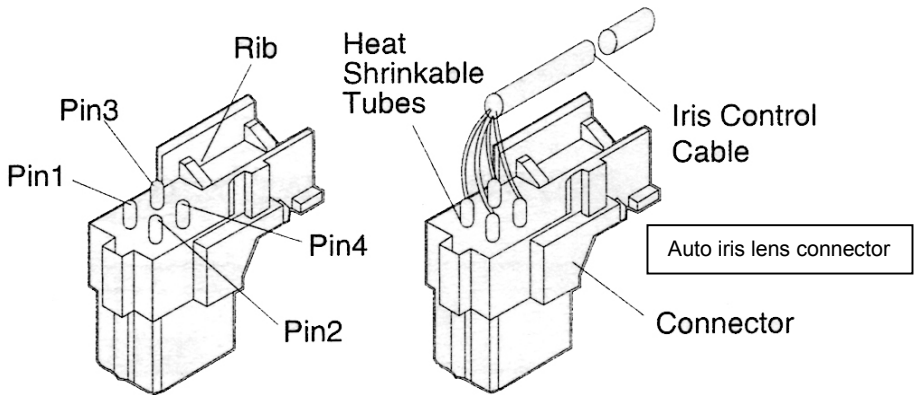

Cut the iris connector cable at the edge of the lens connector to remove the existing lens connector and then remove the outer cable cover of the supplied connector as shown in the diagram. Solder the lens cable to the pins of the supplied connector.

4. Mounting the Lens

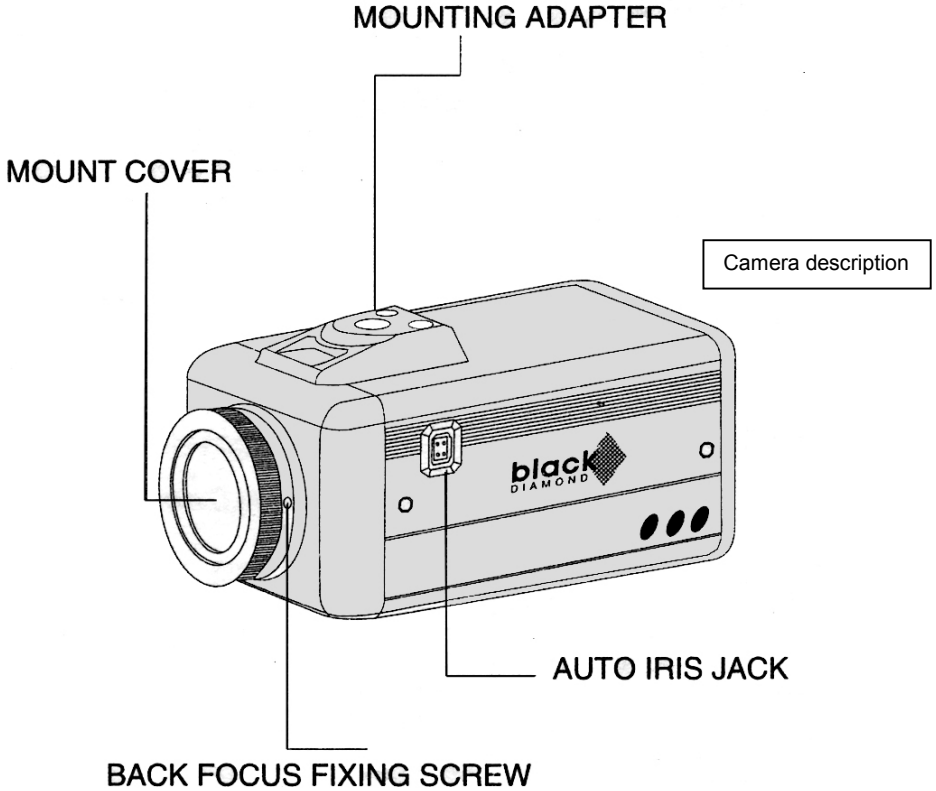

1. Set up the lens by turning it clockwise on the lens mount of the camera. In case you are using a CS-Mount Lens connect the CS-Mount Adapter to the lens first and then mount it to the camera body.
2. Connect the lens cable to the Auto Iris Lens Connector on the side of the camera.
3. Adjust the Auto Iris Lens Selection Switch on the back (see page: 7) according to the used lens: To Video (**V/D**) for video controlled iris lens or **DC** for DC controlled iris lens.
4. Adjust back focus, when ready, fix the lens with the Back Focus Fixing Screw.
5. DC Level DC Auto Iris Lens Level Adjustment (see page: 7).
Adjust under normal light conditions the DC Level with a fine screw driver to the best picture performance.

5. Operating controls and functions

Function switch on the back (see page: 7)

| S/W | Function | ON | OFF |
|-----|----------|-----|-----|
| 1 | BLC | ON | OFF |
| 2 | ALC | E/S | ALC |
| 3 | --- | --- | --- |
| 4 | AGC | MIN | MAX |

S/W 1 Back Light Compensation Mode Selector
(BLC ON, OFF)

Lets you select the mode according to the position of the object and light conditions on the screen.

S/W 2 Automatic Light Control / Electronic Light Control Selector
(ALC; E/S)

Lets you select the mode according to the lens type used.

ALC: Select this mode when an auto iris lens (ALC lens) is used with this camera.

E/S: Select this mode when a fixed iris lens or manual iris lens is used with this camera.

S/W 3 Not Used / No Function

S/W 4 Automatic Gain Control

Auto Iris Lens Selection Switch (see page: 7)

- V/D = Video Signal controlled
- DC = DC controlled (DC Level adjustment)

DC Level DC Auto Iris Lens Level Adjustment (see page: 7).
Adjust under normal light conditions the DC Level with a fine screw driver to the best picture performance.

SPECIFICATION

| | |
|--|--|
| Model Name | BDC4803H |
| Signal Standard | PAL |
| Objective Mount | C-Mount and CS-Mount (adapter) |
| CCD – Chip | 1/3" Super HAD CCD |
| Scanning System | 2:1 Interlaced |
| Scanning Frequency | H: 15.625 kHz V: 50 Hz |
| Total Pixels | 795 (H) x 596 (V) app. 470.000 Pixel |
| Effective Pixels | 752 (H) x 582 (V) app. 440.000 Pixel |
| Horizontal Resolution | 480 Lines |
| Electronic Shutter | 1/50 – 1/1000000 auto 1/50 fix |
| S/N Ratio | > 45 dB (AGC off) |
| Sensitivity | 1.0 Lux @ F 2.0 |
| Sync System | Internal Sync |
| Automatic Iris Control | Yes, DC or Video controlled |
| White Balance | Automatic |
| Function | BLC, ALC, AGC |
| Video Output | 1 Vpp 75 Ω unbalanced |
| Power Source | DC 12 V (\pm 10 %) |
| Power Consumption | max. 180 mA (2,2 W) |
| Operating Temperature | -10 °C ~ +50 °C |
| Operating Humidity | max. 80 % without dew |
| Dimensions (W x H x D mm) (without connector) | 53 x 42 x 99 mm |
| Weight (without Lens) | 270 g |
| Approvals | CE EN 55022 EN 55024 EN 61000 |

ADDRESS



Electronic Visual Systems

MITSUBISHI ELECTRIC EUROPE B.V.

Gothaer Strasse 8 40880 Ratingen Postfach 1548 40835 Ratingen Germany
Telefon +49 (2102) 486 - 9250 Telefax +49 (2102) 486 - 7320

(Technical specifications subject to change. No liability will be assumed for printing errors or other errors.)